

NEW CONCEPT

TECHNICAL CHARACTERISTICS

POWER (W)	1700
AIRFLOW (m ³ /H)	210
WATER LIFT (mm/H ₂ O)	2600
BIN CAPACITY (L)	5
WEIGHT (kg)	7.85
NOISE LEVEL (dB)	61
AIRWATTS (W)	480

VIEW FROM ABOVE

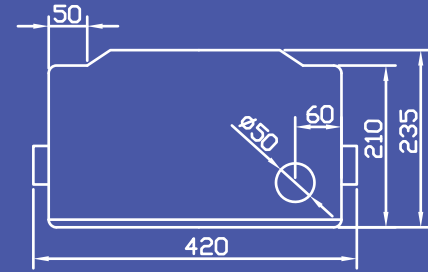

VACUUM

EXHAUST



LED PANEL

FRONT VIEW

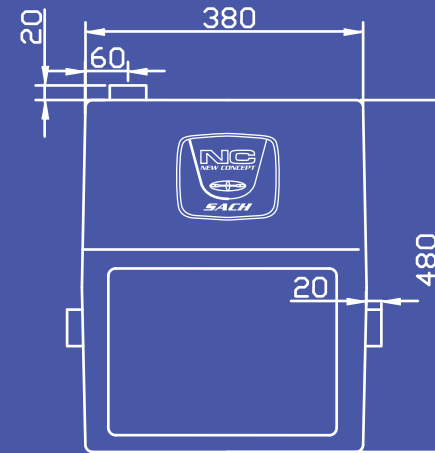

SIDE VIEW

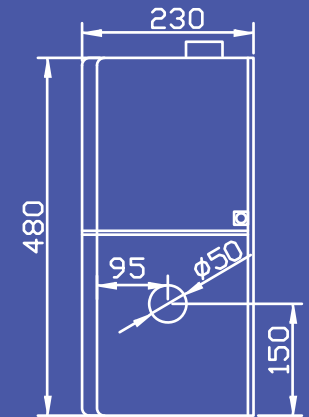

RECOMMENDATIONS FOR INSTALLATION

DWELLING SIZE IN m ²	< 200
FURTHEST VALVE FROM THE UNIT (ml)	25
NUMBER OF VALVES	4

www.sachvac.com

