

VAC digital 2.4



1. Level power indicator
2. Hepa filter indicator
3. Electrical protection indicator
4. Total hours of use
5. Bin full indicator
6. Motor maintenance indicator

TECHNICAL CHARACTERISTICS

Power (W)	2400 (2x1200)
Air-Flow (m ³ /h)	294
Waterlift (mm/H ₂ O)	2800
Airwatts	835
HEPA filter surface area (cm ²)	6000
Pro-Tecta filter surface area (cm ²)	1300
Bin capacity (L)	28
Noise level (dB)	≤60
Weight (kg)	17

2x High-speed through-flow motor

RECOMMENDATIONS FOR INSTALLATION

Dwelling size in m ²	≤900
Furthest valve from the unit (lm)	60
Maximum number of inlet valves	20

Box size



39x46x105cm

Pallet size (12 pcs)

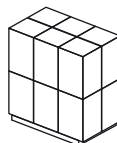

80x138x225cm

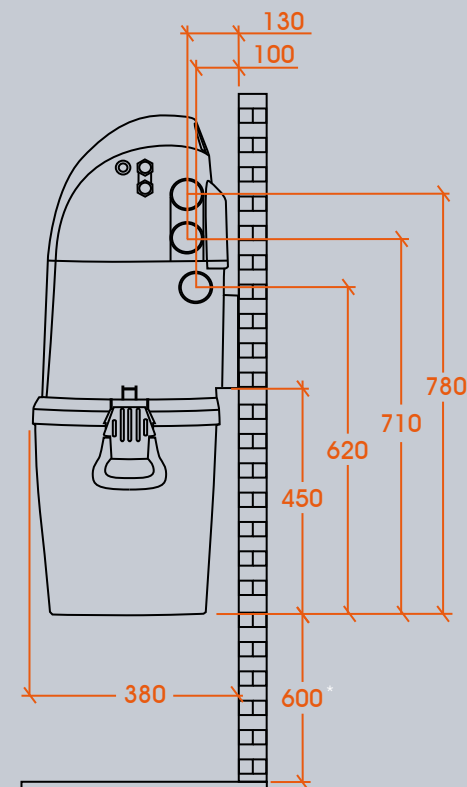
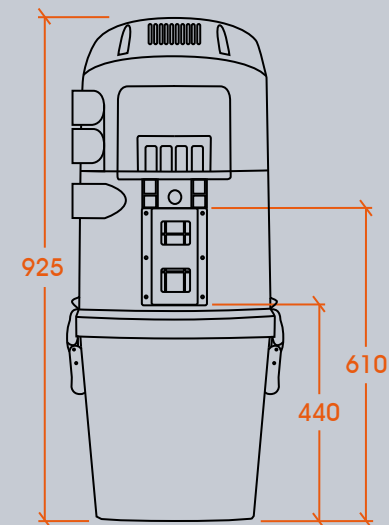
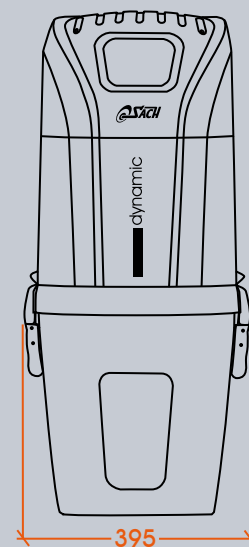

Wall hanger detail

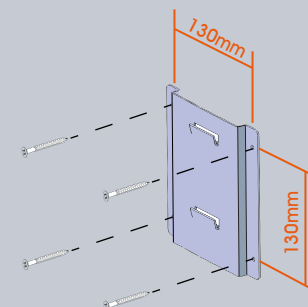

* Minimum space recommended to allow the dust container to be emptied comfortably.