

VAC digital 1.8



1. Level power indicator
2. Hepa filter indicator
3. Electrical protection indicator
4. Total hours of use
5. Bin full indicator
6. Motor maintenance indicator

TECHNICAL CHARACTERISTICS

Power (W)	1800
Air-Flow (m ³ /h)	210
Waterlift (mm/H ₂ O)	3300
Airwatts	643
HEPA filter surface area (cm ²)	6000
Pro-Tecta filter surface area (cm ²)	1300
Bin capacity (L)	28
Noise level (dB)	≤60
Weight (kg)	16

High speed By-Pass peripheral motor

RECOMMENDATIONS FOR INSTALLATION

Dwelling size in m ²	≤500
Furthest valve from the unit (lm)	50
Maximum number of inlet valves	12

Box size  39x46x89cm

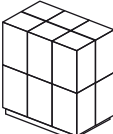
Pallet size (12 pcs)  80x138x193cm

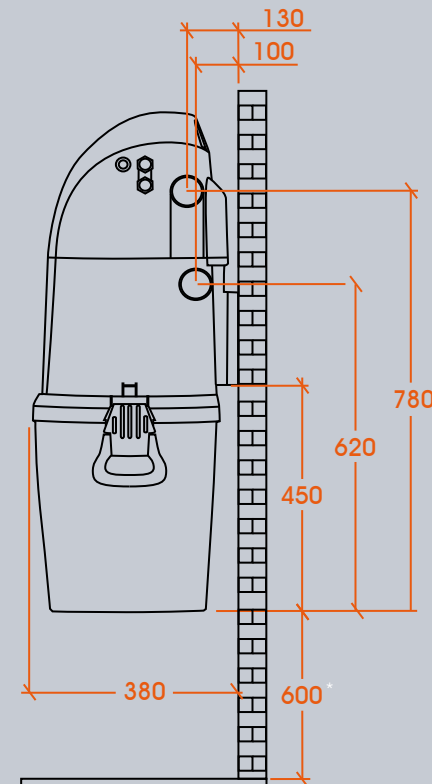
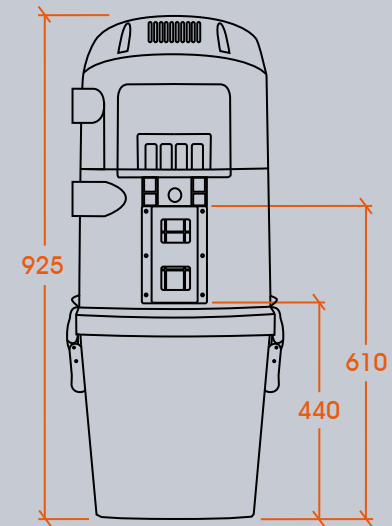
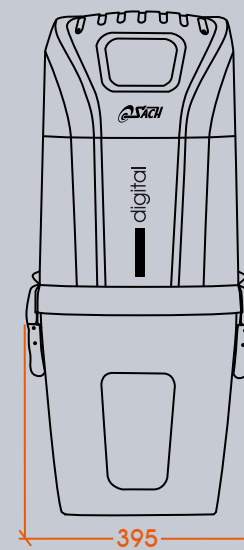

Wall hanger detail

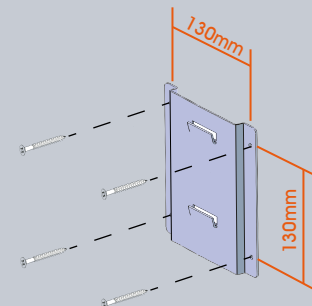

* Minimum space recommended to allow the dust container to be emptied comfortably.