

FFD 9469 CV GCC

12NC: 859991658340

GTIN (EAN) code: 8003437640308

Whirlpool

SENSING THE DIFFERENCE

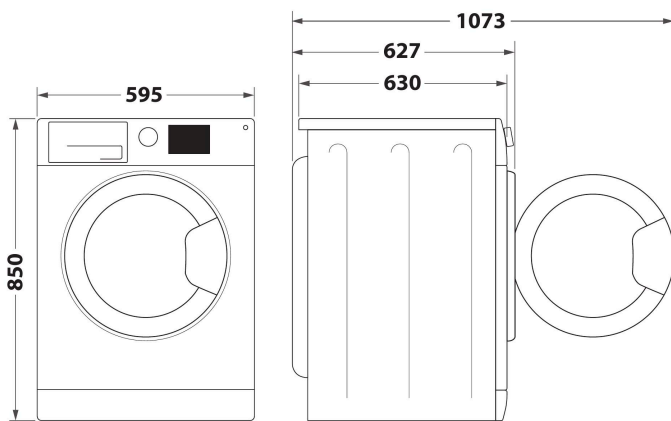
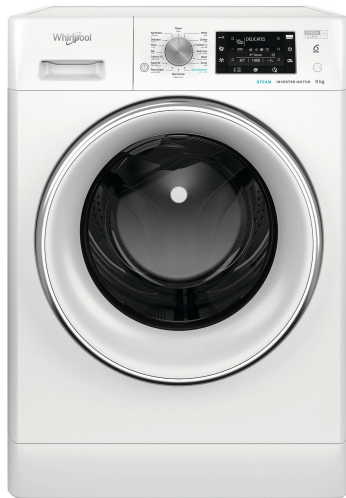

- Energy class A+++
- Washing capacity: 9 kg
- Maximum spin speed: 1400 rpm
- 6TH Sense Technology
- FreshCare+
- Daily 30°
- Daily 40°
- Daily mixed 40°C
- Rapid
- Eco Cotton
- Steam refresh
- Mixed Fabrics Program
- Special Big Items Program
- Sport
- Lingerie Program
- Delicates
- Program Progress Indicators

Whirlpool freestanding front loading washing machine: 9 kg - FFD 9469 CV GCC

This Whirlpool freestanding Washing Machine features: white color. A spacious, large 9kg capacity. A fast, resource-efficient 1400 revolutions per minute spin speed. Exclusive 6th SENSE technology, that dynamically adapts settings to each specific load, ensuring ideal care for all your fabrics. 30 minute quick wash.



6th Sense Technology

Discover perfect care. 6th SENSE intelligent sensors adapt resources according to the size and type of load, offering time, energy and water optimization.



Steam Hygiene

Laundry is sanitized in the most natural and delicate way at the end of the washing cycle - even when washing at low temperatures - without chemical additives. Ideal for those with sensitive skins, and good for the environment as well, this treatment removes up to 99.9% of the most common bacteria.



FreshCare+

100% Freshness even if you forget to unload. No need to adapt your schedule to the laundry chores: your garments will be protected from odours and creasing. FreshCare+ thanks to delicate steaming and tumbling action inhibits the proliferation of the main bad odour sources (inside the washer) for up to 6 hours after the cycle ends, while gentle tumbling prevents fixing of creases.



Sense Inverter Motor

Silent performance. This Whirlpool Washing machine's innovative SENSE Inverter Motor is designed to ensure a long lasting, silent performance. Enjoy both ideal results and some extra peace and quiet.



1400 rpm

Outstanding speed. This Whirlpool Washing Machine features a 1400 rounds per minute spin speed.



Inverter Motor

Silent performance. This Whirlpool Washing machine's innovative Inverter Motor is designed to ensure a long lasting, silent performance. Enjoy both ideal results and some extra peace and quiet.



9kg Capacity

All the space you need. With its 9kg drum capacity, this Whirlpool Washing Machine provides all the space you need for your laundry.

FFD 9469 CV GCC

12NC: 859991658340

GTIN (EAN) code: 8003437640308

Whirlpool

SENSING THE DIFFERENCE

MAIN FEATURES

Product group	Washing machine
Construction type	Free-standing
Installation type	Free-standing
Removable work top	No
Loading type	Front loader
Main colour of product	White
Electrical connection rating (W)	1850
Current (A)	13
Voltage (V)	220-240
Frequency (Hz)	50
Length of Electrical Supply Cord (cm)	120
Plug type	UK
Height of the product	850
Width of the product	595
Depth of the product	630
Net weight (kg)	71

TECHNICAL FEATURES

Automatic programmes	Yes
Spin speed options	Variable
Skip spin	Yes
Weight measurement	-
Textile type recognition	-
Degree of dirtiness recognition	-
Foam control	Yes
Balance control	Yes
Type of water protection system	No
Cold wash option	No
Progress indicator	-
Digital countdown indicator	Yes
Start delay options	Continuous
Start delay time max. (h)	0
Tub material	Plastic
Drum volume (l)	62
Hot & cold water intake?	No
Gross weight (kg)	72
Height of the packed product	870
Width of the packed product	640
Depth of the packed product	645

ENERGIA - ЕНЕРГИЈА - ENERGIJA - ENERGIJA - ENERGIJA - ENERGIJA - ENERGIJA - ENERGIJA - ENERGIJA - ENERGIJA

WHIRLPOOL
FFD 9469 CV GCC

A+++

152
kWh/annum

12350 L/annum

9 kg

52 dB

78 dB

2010/1061

PERFORMANCES

Energy efficiency class - NEW (2010/30/EU)	A+++
Energy consumption annual (kWh/annum) - NEW (2010/30/EU)	152
Washing performance class	A
Maximum spin speed (rpm) - NEW (2010/30/EU)	1400
Capacity cotton (kg) - NEW (2010/30/EU)	9
Water consumption annual (l/annum) - NEW (2010/30/EU)	12350
Energy consumption 60 °C full load	0.742
Power consumption in left-on mode - NEW (2010/30/EU)	8
Power consumption in off-mode - NEW (2010/30/EU)	0.5
Moisture content % on dry load after max. spin - NEW (2010/30/EU)	53
Average washing time cotton 60°C (full load) - NEW (2010/30/EU)	260
Noise level washing (dB(A) re 1 pW)	52
Noise level spinning (dB(A) re 1 pW)	78