

# WHBS 95 LM K

12NC: 859991566130

GTIN (EAN) code: 8003437236341

Whirlpool

SENSING THE DIFFERENCE

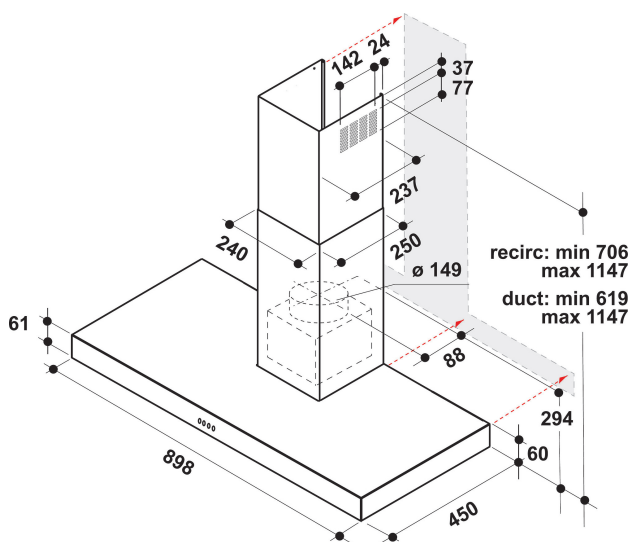

- Maximum noise level 65 dBA
- Noise Level (min. - max.): 57-65 dBA
- Air Flow (min. - max.): 302, 428 m<sup>3</sup>/h
- Maximum extraction rate: 428 (m<sup>3</sup>/h)
- Energy class D
- Extraction / Recirculation Rate 432 / 155 m<sup>3</sup>/h
- 2 LED, 6 W lamps
- 1 x 140 W motor
- Mechanical Buttons
- 3 Washable aluminium filters
- Grease Filtering Efficiency Class: C
- Lighting Efficiency Class: D
- Fluid Dynamic Efficiency Class: E
- Operating Mode: Air extraction, Recirculating air
- Inox Finishing
- 1 Motor
- Motor Power: 140 W

## Whirlpool wall mounted cooker hood - WHBS 95 LM K

This Whirlpool wall mounted Cooker Hood features: black color. Dishwasher-safe, washable aluminium grease filters. LED lights for ideal lighting. An outstanding cooker extractor fan, ensuring a fresh, grease-free cooking environment. Between 60cm and 90cm wide appliance.



### LED lighting

Increased energy and cost efficiency. The LED lighting system lasts 10 times longer than traditional bulbs and uses 90% less energy.



### Flexible Installation

Flexible installation options. This Whirlpool Hood can be operated in either Ducted or Recirculated mode (filter needed), so you can enjoy complete freedom when designing your kitchen.



### Mechanical control

Effortless control. This Whirlpool Hood includes an analogue control interface designed for simplicity and ease-of-use.



### Wall-mounted installation

Wall-mounted installation. This wall-mounted Whirlpool Hood is a breeze to install.



### Total annual energy consumption

Ideal performance, outstanding savings. Whirlpool Hoods are designed to provide exceptional results, while reducing energy costs.



### TIMER

Perfect timing. This Whirlpool Hood includes an intuitive timer, for added convenience.



### 2 lights

Perfect lighting. This Whirlpool Hood features two integrated lights, providing ideal illumination, so you'll always be able to see what's cooking.



### Energy class D

This is an Energy Class D appliance.

# WHBS 95 LM K

12NC: 859991566130

GTIN (EAN) code: 8003437236341

**Whirlpool**

SENSING THE DIFFERENCE

## MAIN FEATURES

Product group	Hood
Colour body	Black
Material body	Stainless steel
Colour chimney	Inox
Material chimney	Stainless steel
Typology	Wall-mounted
Installation type	Wall-mounted
Type of control	Mechanical
Type of control settings	-
Decor panel options	N/A
Motor location	Integrated motor in hood chimney
Operating Mode	Convertible
Electrical connection rating (W)	146
Current (A)	1,6
Voltage (V)	220-240
Frequency (Hz)	50/60
Length of Electrical Supply Cord (cm)	150
Plug type	Schuko
Chimney height (mm)	-
Height of product, without chimney (mm)	0
Height of the product	1150
Width of the product	898
Depth of the product	450
Minimum niche height	0
Minimum niche width	0
Niche depth	0
Net weight (kg)	18.3

## TECHNICAL FEATURES

Type of manual control devices	Buttons
Type of automatic control devices	-
Number of motors	1
Total power of the motors (W)	140
Number of speed settings: boost option availability	0
Boost presence	No
Maximum output air extraction (m <sup>3</sup> /h)	428
Boost position air extraction (m <sup>3</sup> /h)	0
Maximum output recirculating air (m <sup>3</sup> /h)	155
Boost position output recirculating (m <sup>3</sup> /h)	0
Light Control Type	On/Off
Number of lights	2
Type of lamps used	LED
Total power of the lamps (W)	6
Diameter of air outlet (mm)	150
No-return airflow flap	No
Grease filter material	Washable aluminium
Odour filter	No

## PERFORMANCES

Sound power at min. speed (2010/30/EU)	57
Sound power at max. speed (2010/30/EU)	65
Noise level with boost position (dB(A) re 1 pW)	0

