

# AKP 735 IX

12NC: 857773501500

GTIN (EAN) code: 8003437937552

Whirlpool

SENSING THE DIFFERENCE



## Whirlpool built in electric oven: inox color - AKP 735 IX

This Whirlpool built in Oven features: conventional cooking method. Advanced electric technology allowing you to cook dishes saving energy. Halogen lamp allowing a more energy-efficient performance.



### Absolute aesthetic

The Absolute collection. Admire the beauty of performance. With a futuristic design and unparalleled performance, the Absolute collection is designed for modern, high-tech kitchens. Equipped with innovative 6TH SENSE technology, Absolute ovens can be set in three simple steps for perfect results. Maximum flexibility and ease of use with a distinctive look and original finishes.



### Standard cavity

This Whirlpool Oven features a standard-size cavity.



### Energy class

Outstanding energy savings. Ovens with an A/ A+ energy rating offer an excellent level of energy efficiency, ensuring lower consumption and saving you money on your energy bills.



### Energy class A

Energy efficient. With its A energy rating, this Whirlpool appliance will allow you to enjoy both ideal performance and excellent energy consumption.

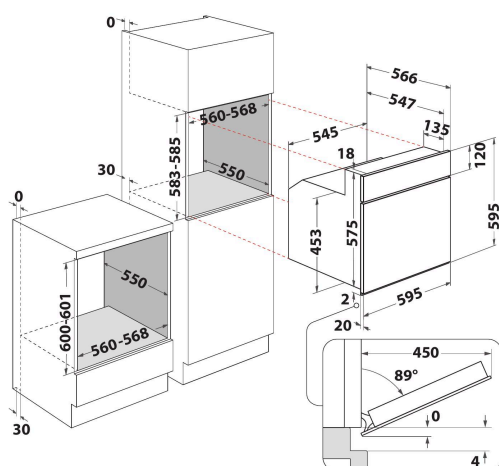

- Energy class A
- Cavity 69 L
- Grill
- Easy Clean Enamel Interior
- Conventional Cooking
- Metal handle
- Door Glasses Number: 2
- Protuding handle
- Grill 1400 W
- 1 Grid
- 1 Tray
- Dark Grey Glass and N/A Bottom Front Trim
- Dimensions HxWxD: 595x595x564 mm
- Product Segment: Absolute Inox

# AKP 735 IX

12NC: 857773501500

GTIN (EAN) code: 8003437937552

# Whirlpool

SENSING THE DIFFERENCE

## MAIN FEATURES

Product group	Oven
Commercial code	AKP 735 IX
Main colour of product	Inox
Construction type	Built-in
Type of control	Mechanical
Type of control settings	-
Are any hobs controls integrated?	No
Which kind of hobs can be controlled?	-
Automatic programmes	No
Current (A)	13
Voltage (V)	220-240
Frequency (Hz)	50/60
Length of Electrical Supply Cord (cm)	90
Plug type	No
Depth with open door 90 degree (mm)	-
Height of the product	595
Width of the product	595
Depth of the product	564
Minimum niche height	0
Minimum niche width	0
Niche depth	0
Net weight (kg)	34
Usable volume (of cavity)	69
Integrated Cleaning system	No
Grids of the cavity	1
Trays	1

## TECHNICAL FEATURES

Timer	No
Time control	No control of the time
Time-setting options	No delay options
Safety device	-
Interior light	Yes
Number of interior lights of the cavity	1
Position of interior lights of the cavity	Rear
Oven guides of the cavity	Grids
Probe of the cavity	No

## PERFORMANCES

Energy input	Electric
Type of energy of the cavity	Electricity
Energy efficiency class - NEW (2010/30/EU)	A
Energy consumption per cycle conventional - NEW (2010/30/EU)	0.8
Energy consumption per cycle forced air convection - NEW (2010/30/EU)	0



**ENERG** Y UA  
енергия · ενεργεια IE 1A

**WHIRLPOOL** AKP 735 IX



A



**69** L



**0.8** kWh/cycle\*



**0** kWh/cycle\*

\* цистерна · cylindus · partion · zylinder · nádvarpajusa · cilindro · tsükkel · ohjelma · cilindus · cilindro · ciklus · cylindus · cylindro · cilidru · program · cykel

65/2014