

# ADG 100

12NC: 851151015000

GTIN (EAN) code: 8003437244896

**Whirlpool**

SENSING THE DIFFERENCE

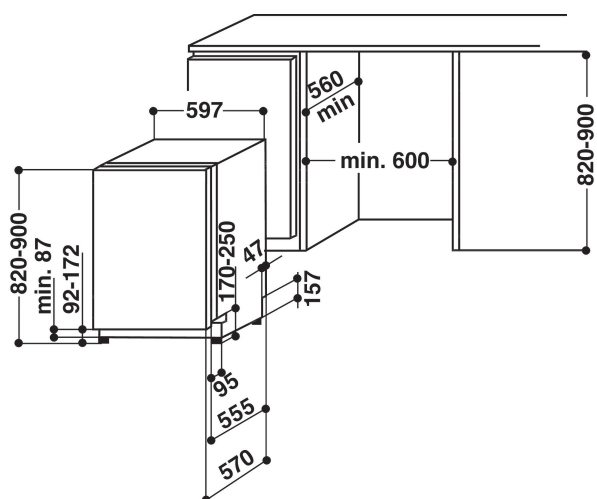

## MAIN FEATURES

Construction type	Built-in
Installation type	Full-integrated
Type of control	Mechanical and electronic
Type of control settings	LED
Removable work top	N/A
Door decor panel	N/A
Main colour of product	Silver
Electrical connection rating (W)	2400
Current (A)	13
Voltage (V)	230-240
Frequency (Hz)	50
Length of Electrical Supply Cord (cm)	150
Plug type	UK
Length inlet hose (cm)	150
Length outlet hose (cm)	200
Adjustable plinth	No
Height of removable worktop (mm)	0
Adjustable feet	Yes - all
Height of the product	820
Width of the product	597
Depth of the product	555
Depth with open door 90 degree (mm)	1150
Minimum niche height	820
Maximum niche height	900
Minimum niche width	600
Maximum niche width	600
Niche depth	560
Net weight (kg)	41
Gross weight (kg)	42.2

## TECHNICAL FEATURES

Automatic programmes	No
Maximum temperature for water intake (°C)	25
Start delay options	One time fixed
Start delay time max. (h)	8
Progress indicator	No
Digital countdown indicator	No
Salt light indicator	Yes
Rinse aid light indicator	Yes
Safety device	No
Adjustable upper basket	Yes
Largest loadable dish upper basket (cm)	0
Largest loadable dish lower basket (cm)	0

## PERFORMANCES

Energy efficiency class - NEW (2010/30/EU)	A+
Energy consumption annual (kWh/annum) - NEW (2010/30/EU)	291
Duration of the left-on mode - NEW (2010/30/EU)	3
Power consumption in left-on mode - NEW (2010/30/EU)	1.5
Power consumption in off-mode - NEW (2010/30/EU)	0.5
Water consumption annual (l/annum) - NEW (2010/30/EU)	3360
Noise level (dB(A) re 1 pW)	48