

# WP 69 IX

12NC: 851168065010

GTIN (EAN) code: 8003437242311

**Whirlpool**

SENSING THE DIFFERENCE

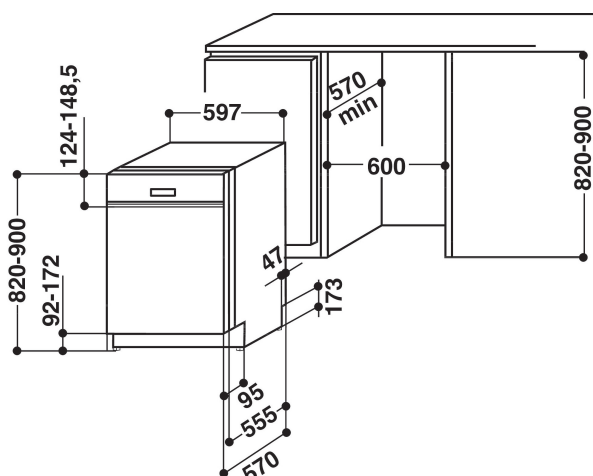

## MAIN FEATURES

Construction type	Built-in
Installation type	Half-integrated
Type of control	Mechanical and electronic
Type of control settings	7 segments
Removable work top	No
Door decor panel	-
Main colour of product	Inox
Electrical connection rating (W)	2400
Current (A)	13
Voltage (V)	230-240
Frequency (Hz)	50
Length of Electrical Supply Cord (cm)	150
Plug type	UK
Length inlet hose (cm)	150
Length outlet hose (cm)	200
Adjustable plinth	No
Height of removable worktop (mm)	0
Adjustable feet	Yes - all from front
Height of the product	820
Width of the product	597
Depth of the product	570
Depth with open door 90 degree (mm)	1150
Minimum niche height	820
Maximum niche height	900
Minimum niche width	600
Maximum niche width	600
Niche depth	570
Net weight (kg)	43
Gross weight (kg)	44.2

## TECHNICAL FEATURES

Automatic programmes	Yes
Maximum temperature for water intake (°C)	60
Start delay options	Continuous
Start delay time max. (h)	24
Progress indicator	Yes
Digital countdown indicator	Yes
Salt light indicator	Yes
Rinse aid light indicator	Yes
Safety device	N/A
Adjustable upper basket	Yes
Largest loadable dish upper basket (cm)	0
Largest loadable dish lower basket (cm)	0

## PERFORMANCES

Energy efficiency class - NEW (2010/30/EU)	A+
Energy consumption annual (kWh/annum) - NEW (2010/30/EU)	295
Duration of the left-on mode - NEW (2010/30/EU)	3
Power consumption in left-on mode - NEW (2010/30/EU)	1.5
Power consumption in off-mode - NEW (2010/30/EU)	0.5
Water consumption annual (l/annum) - NEW (2010/30/EU)	3220
Noise level (dB(A) re 1 pW)	46