

AKT 8800 /BF

12NC: 859991538540

GTIN (EAN) code: 8050147538548

Whirlpool

SENSING THE DIFFERENCE



Whirlpool hob - AKT 8800 /BF

This Whirlpool Hob features: electric power supply.



Front Controls

Complete control over your cooking. Easily accessible and genuinely intuitive, the controls are conveniently positioned on the front panel of your hob, providing a frictionless cooking experience.

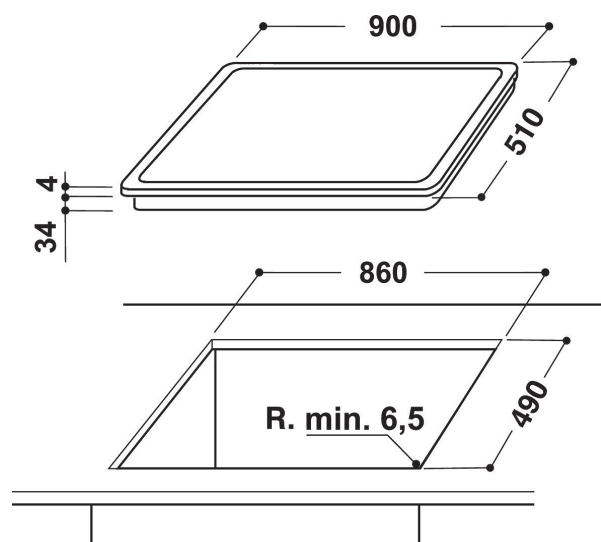

- Child lock
- On/Off Switch
- 90 cm hob
- Timer
- Black Glass Hob
- 5 Radiant cooking zones
- Supply cord included
- 1 side bevelled
- Dimensions HxWxD: 40x900x510 mm
- Electrical Connection Rating: 8900 W
- Voltage: 220-240 V
- Pause Function

AKT 8800 /BF

12NC: 859991538540

GTIN (EAN) code: 8050147538548

Whirlpool

SENSING THE DIFFERENCE

MAIN FEATURES

Product group	Hob
Construction type	Built-in
Type of control	Electronic
Type of control settings	-
Number of gas burners	0
Number of electric cooking zones	0
Number of electric plates	0
Number of radiant plates	5
Number of halogen plates	0
Number of induction plates	0
Number of electric warming zones	0
Location of control panel	Front
Basic surface material	Ceramic Glass
Main colour of product	Black
Electrical connection rating (W)	8900
Gas connection rating (W)	0
Current (A)	0
Voltage (V)	220-240
Frequency (Hz)	50/60
Length of Electrical Supply Cord (cm)	0
Plug type	No
Gas connection	N/A
Width of the product	900
Height of the product	40
Depth of the product	510
Minimum niche height	0
Minimum niche width	0
Niche depth	0
Net weight (kg)	12.5
Automatic programmes	No

TECHNICAL FEATURES

Power on indicator	No
Number of indicators	0
Type of regulation	Temperature regulated
Type of lid	Without
Residual heat indicator	Without
Main on/off switch	Yes
Safety device	-
Timer	Yes

PERFORMANCES

Energy input	Electric
--------------	----------