

AKG 619 IX

12NC: 853561901000

GTIN (EAN) code: 8003437213779

Whirlpool

SENSING THE DIFFERENCE

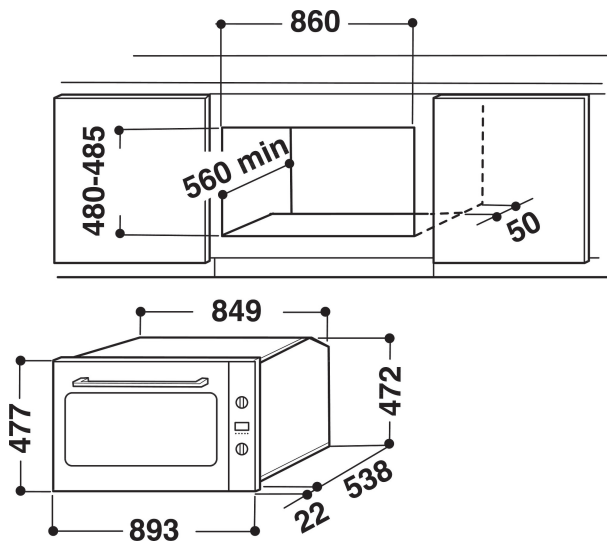

Whirlpool built in electric oven: inox color - AKG 619 IX

This Whirlpool built in Oven features: advanced electric technology allowing you to cook dishes saving energy. Innovative Cook3 function, that allows you to cook up to three separate dishes at the same time, without the risk of aromas mixing.



Cook3

No aroma mixing. With the innovative Cook3 function, you can cook up to three separate dishes at the same time, without the risk of aromas mixing.



Multifunction 8

Multiple cooking methods. The Multifunction 8 feature offers flexible cooking options, to ensure perfect results, whatever the recipe.



XXL cavity

All the space you need. The XXL cavity in your oven has a capacity of 75 litres with 5 different shelf positions available.



Energy class

Outstanding energy savings. Ovens with an A/ A+ energy rating offer an excellent level of energy efficiency, ensuring lower consumption and saving you money on your energy bills.



Energy class A

Energy efficient. With its A energy rating, this Whirlpool appliance will allow you to enjoy both ideal performance and excellent energy consumption.

- Energy class A
- Cavity 89 L
- Cook3
- Defrost function
- Forced Air Fan Cooking
- Turbo Fan
- Grill
- Easy Clean Enamel Interior
- Turbo grill function
- Pastry function
- Conventional Cooking
- Metal handle
- Door Glasses Number: 2
- Protuding handle
- Switch-off timer
- Grill 2850 W
- 2 Grids

AKG 619 IX

12NC: 853561901000

GTIN (EAN) code: 8003437213779

Whirlpool

SENSING THE DIFFERENCE

MAIN FEATURES

Product group	Oven
Commercial code	AKG 619 IX
Main colour of product	Inox
Construction type	Built-in
Type of control	Mechanical
Type of control settings	-
Are any hobs controls integrated?	No
Which kind of hobs can be controlled?	-
Automatic programmes	No
Current (A)	13
Voltage (V)	220-240
Frequency (Hz)	50/60
Length of Electrical Supply Cord (cm)	110
Plug type	No
Depth with open door 90 degree (mm)	-
Height of the product	477
Width of the product	893
Depth of the product	538
Minimum niche height	0
Minimum niche width	0
Niche depth	0
Net weight (kg)	51
Usable volume (of cavity)	75
Integrated Cleaning system	No
Grids of the cavity	2
Trays	1

TECHNICAL FEATURES

Timer	-
Time control	Mechanical
Time-setting options	Stop
Safety device	-
Interior light	Yes
Number of interior lights of the cavity	2
Position of interior lights of the cavity	Rear
Oven guides of the cavity	Grids
Probe of the cavity	No

PERFORMANCES

Energy input	Electric
Type of energy of the cavity	Electricity
Energy efficiency class - NEW (2010/30/EU)	A
Energy consumption per cycle conventional - NEW (2010/30/EU)	0.98
Energy consumption per cycle forced air convection - NEW (2010/30/EU)	0.82



ENERG Y UA
енергия · ενεργεια IE 1A

WHIRLPOOL AKG 619 IX



A



89 L



0.98 kWh/cycle*



0.82 kWh/cycle*

* цистерна · cylindus · partion · zylinder · nádvarpajusa · ciclo · tsükkel · ohjelma · ciklus · ciklus · ciklu · cycles · cykl · ciclu · program · cykel

65/2014